

# **Refinery Wastewater Management Using Multiple – Angle Oil Water Separators**

John N. Veenstra, Ph.D., P.E.,  
Oklahoma State University,  
Kirby S. Mohr, P.E.  
Mohr Separations Research, Inc.  
and Dee Ann Sanders, Ph.D., P.E.  
Oklahoma State University

A paper presented at the  
International Petroleum Environment Conference  
Albuquerque, New Mexico  
October, 1998

# **Refinery Wastewater Management Using Multiple – Angle Oil Water Separators**

John N. Veenstra, Ph.D., P.E.,  
Oklahoma State University,  
Kirby S. Mohr, P.E.  
Mohr Separations Research, Inc.  
and Dee Ann Sanders, Ph.D., P.E.  
Oklahoma State University

## **Abstract**

In this work, an overview of oil-water separation as used in the petroleum refining industries is presented along with case studies. Discussions include impact of solids, legal aspects, and differing types of systems currently in use along with advantages and disadvantages. Performance information on separators is presented with emphasis on new multiple-angle coalescing plate technology for refinery wastewater management.

Several studies are presented including a large (20,000 US gpm flow rate) system recently installed at a major US refinery. The separator was constructed by converting two existing API separators into four separators and adding multiple-angle coalescing plates to increase throughput and efficiency. A year of operating experience with this system indicates good performance and few problems. Other examples provide information on separators installed in the United States and other countries.

Keywords:

oil-water separator, coalescence, refinery, wastewater,

# Refinery Wastewater Management Using Multiple – Angle Oil Water Separators

John N. Veenstra, Ph.D., P.E.,  
Oklahoma State University,  
Kirby S. Mohr, P.E.  
Mohr Separations Research, Inc.  
and Dee Ann Sanders, Ph.D., P.E.  
Oklahoma State University

## Background and Introduction

Oil has been refined for various uses for at least 1000 years. An Arab handbook written by Al-Razi in approximately 865 A.D. describes distillation of “naft” (naphtha) for use in lamps and thus the beginning of oil refining (1). The main product of early commercial-scale refineries was kerosene, used as a substitute for whale oil. Gasoline and heavier fractions were considered waste disposal problems (2).

Oil production and oil refinery wastewater streams have caused environmental problems for many years. In the 1950's Soviet refineries were discharging wastewater containing up to 4000 mg/L of oil on a regular basis (3). As late as 1973, German law required only 95% removal of oil. This has the implication that of 100 L of fuel oil entered a refinery separator, 5 L could exit with the outlet water, rendering about 5 million L of water undrinkable (4).

Refinery effluent water contains various hydrocarbon components including gasoline blending stocks, kerosene, diesel fuel and heavier liquids. Also present may be suspended mineral solids, sand, salt, organic acids and sulfur compounds. The nature of the components depends on the constituents of the inlet crude oil as well as the processing scheme of the refinery (5). Most of these constituents would be undesirable in the effluent water, so it is necessary to treat the water to remove the contaminants.

## Legal Considerations

In 1965, a United States District Court found that an accidental discharge of aviation gasoline into navigable waters did not constitute a violation of the Rivers and Harbors Act of 1899 because gasoline ‘was not such as to impede navigation’(6). A few years later, in 1973, the United States Supreme Court ruled that the Congress did intend the regulation of pollutants under both the Rivers and Harbors Act and the Clean Water Act (6).

© Kirby S. Mohr, 1998

In the United States, refinery outfall water quality is governed by National Pollutant Discharge Elimination System (NPDES) permits granted under the Clean Water Act. Administration is generally by the various state environmental agencies under the supervision of the United States Environmental Protection Agency (EPA).

In addition to regulating outfalls from the process sewers, the Clean Water Act passed in 1972 required the EPA to set up a stormwater management program to manage the stormwater discharge from industrial and construction sites under NPDES permits. This includes sites that have any rainwater effluent from outdoor storage of either raw materials or finished goods. Included in individual permit applications are a quantitative requirements for “oil and grease”, TSS, COD, pH, BOD, total phosphorous, TKN, and nitrate plus nitrite nitrogen. Sampling for contaminants is mandated, and samples must be collected from the discharge resulting from a storm greater than 0.1 inch, and at least 72 hours from the latest measurable storm event (7). All US refineries have NPDES permit requirements they must meet to remain in operation.

## **Toxic and Other Undesirable Effects of Oil on Life**

Undesirable effects of hydrocarbons in water include taste and odor contamination in addition to toxicity. Petroleum hydrocarbons in concentrations as low as 0.5 mg/L can impart a perceptible unpleasant taste (5) whereas concentrations as low as 10 to 100 µg/L can adversely affect aquatic organisms (8). Napthenic acid from refineries can have a toxic effect on plant and animal life at concentrations as low as 0.5 mg/L (5). Hydrocarbons, especially aromatic hydrocarbons, are toxic and/or carcinogenic to humans and animals as well as to aquatic life where feeding or reproductive behavior may be altered. Cattle drinking water containing oil are often affected by diseases of the alimentary tract (5).

Gasoline is particularly high in aromatic content because aromatic compounds such as benzene and toluene are high octane blending components (2). Most of the components of gasoline are very volatile and tend to evaporate from roadways and parking lots (9) and are therefore not present in stormwater runoff. However, some of these components may still be present in refinery wastewater streams.

## **Sources of Oily Wastewater and Collection Systems**

Wastewater in refineries (other than domestic waste) originates from either process water streams or rainwater, although some coastal refineries will also have ship's ballast water to treat as well (10). The size of most refinery separator systems is determined by the stormwater flow (11).

In some older refineries, the wastewater system was designed to collect all wastewater streams into a single sewer system and direct them together to oil separators, which were sometimes very simple pits and sometimes API separators (2). This sewer design had the undesirable effect that generally oil-free waters, such as lawn and roof runoff, were mixed with more contaminated process sewers and storm runoff water from diked areas, tank car and truck loading facilities.

Ballast water from ships contaminated with light hydrocarbons such as gasoline will contain only small amounts of hydrocarbons until the tanks are almost pumped empty because of separation within the tank, but ballast from tanks containing heavy fuel oils may be expected to have hydrocarbons dispersed throughout. Ballast water may also contain solid particles of silt, sand, clay, and rust (10).

Another possible source of oil in water is cooling water. In many refineries, cooling water systems are closed-loop designs, but some refineries still use once-through systems, particularly coastal refineries and those on large lakes and rivers. One large US inland refinery uses 5.05 m<sup>3</sup>/sec (80,000 US gpm) of water from Lake Michigan for once-through cooling water (12). A real possibility of environmental contamination from once-through cooling water systems exists, and many refinery engineers are considering the risks of contamination and possible safeguards against problems (13).

## Oil in Refinery Wastewater

Oil in a refinery wastewater stream may exist in one or more of three forms (14):

**Free oil:** This is defined as oil in the form of separate oil globules of sufficient size that they can rise as a result of buoyancy force to the top of the water. Separators may readily be designed to remove this type of oil.

**Emulsified oil:** This is oil in the form of much smaller droplets or globules with a diameter of 20 microns or less which form a stable suspension in the water. According to the API, a true emulsion will not separate by gravity “regardless of how long a true oil-water emulsion stands under quiescent conditions.” For design purposes, the term emulsified oil may also be applied to emulsions where the droplets are so small that they will not rise at a rate that allows a practical size separation device. It is possible to design enhanced gravity separators to treat waters containing this type of oil, but generally it is only practical for small flow rates (15).

**Dissolved oil:** Truly dissolved oil may not be removed by gravity separation and other methods must be adopted. Such means include biological treatment, adsorption by activated carbon or other adsorbents or absorbents.

## Separator Efficiency Required

It is generally accepted that a sheen will form on the surface of the water if hydrocarbon concentrations are more than 15 mg/L (16). The presence of a sheen is not acceptable under the conditions of the Clean Water Act, so it is necessary to remove hydrocarbons to an effluent concentration of 15 mg/L or less. The Clean Water Act allows local authorities to set more stringent requirements; and regulations in the Puget Sound, Washington area require an effluent concentration of 10 mg/L or less (17). Some countries have even more stringent rules; for example Canada requires 5 mg/L or less for inland water discharges (18).

In a survey done by the API in 1985 (14), fewer than half of the separators designed according to the API design method were generating effluent qualities less than 100 mg/L. Approximately one third of the separator effluents contained hydrocarbons in excess of 200 mg/L, so API separators are generally not acceptable as final treatment systems. API separators are designed for removal of 150 micron and larger droplets, so it follows that either a substantial percentage of the incoming droplets are smaller than 150 microns or the API separators do not perform as well as they are designed to do.

It is sometimes possible, under favorable conditions to achieve effluent oil contents of 10 mg/L or less with pure gravity separation, but where regulations require oil contents consistently below 10-20 mg/L, systems in addition to gravity separation are normally installed (13). Enhanced gravity systems such as those including coalescing plates or air flotation systems may be used or additional downstream processing may be required.

## Separation by Gravity

Separation of oil from refinery wastewater is carried out almost exclusively by gravity separation using flotation of the oil droplets in the water, either natural or enhanced. Natural gravitational separation is carried out in American Petroleum Institute (API) separators and in large tanks. Enhanced gravitational separation is accomplished in centrifugal units, air flotation and flocculation units, and in the various types of coalescing plate separators (14). Other possible methods of separation such as distillation, reverse osmosis, or adsorption may be generally too expensive or energy intensive to be used in treating the large flow rates encountered in refinery wastewater.

The hydrocarbons in the *influent* of a refinery separator are present in a spectrum of droplet sizes (14). The hydrocarbon content of the separator *effluent* is made up of those small droplets that are not removed by the separator. The droplet size that must be removed to attain a given effluent concentration depends on the specific gravity of the hydrocarbons in the inlet, amount of hydrocarbons present, and the average droplet size present in the inlet stream (19).

To calculate the required size of a gravity separator, it is first necessary to

calculate the rise velocity of the oil droplets. The size of the separator is then calculated by considering the path of a droplet entering at the bottom of one end of the separator and exiting from the other end of the separator. Sufficient volume must be provided in the separator so that the oil droplets entering the separator at the bottom have time to rise to the surface (and be captured there) before the water carrying the droplets exits the opposite end of the separator.

The droplet rise velocity is given by Stokes's law (20):

$$V_p = \frac{G}{(18 \times \mu)} \times (d_p - d_c) \times D^2$$

Where:

- V<sub>p</sub> = droplet settling velocity, cm/sec
- G = gravitational constant, 980 cm/sec<sup>2</sup>
- μ = absolute viscosity of continuous fluid (water), poise
- d<sub>p</sub> = density of particle (droplet), gm/cm<sup>3</sup>
- d<sub>c</sub> = density of continuous fluid, gm/cm<sup>3</sup>
- D = diameter of particle, cm

From the above equation it may be seen that the most important variables are the viscosity of the continuous liquid, density difference between the continuous liquid and the droplet, and the droplet size. After these are known, the rise velocity and therefore the size of separator required may be calculated. Stokes's equation was originally developed to describe the motion of solid particles falling in a liquid, so a droplet rise velocity is a negative number.

Conditions for validity of the Stokes's Law calculation are:

- 1) Particles are spherical,
- 2) Flow is laminar, both horizontally and vertically, and
- 3) Particles are the same size.

For separation of oil droplets from water, these conditions can be met because:

- 1) Oil droplets are spherical because surface tension (more properly interfacial tension between the water phase and the oil) minimizes the surface area, making the droplets spherical.
- 2) In an enhanced gravity separator, flow is laminar because the separator is designed to retain the Reynolds Numbers under the laminar limit. It should be noted that this is very difficult or impossible to attain in an API separator due to the large size of such separators.
- 3) The oil droplets will not be the same size, unless specifically made in a single size in a laboratory, so it is necessary to do numerous rise rate calculations for the various sizes expected to be present in the influent.

The viscosity of the water is readily obtained from literature data. The design of

such separators often requires design over a wide variety of temperatures (and therefore viscosities) to account for summer and winter conditions. Flow rates and hydrocarbon content of the water must be determined or estimated for the particular system.

## **Types of Separators Typically Used in Refinery Wastewater Management**

Many types of separation methods have been used to remove oil from refinery wastewater with varying degrees of success (19). Some of the systems currently in use are:

- API separators
- Flocculation units
- Dissolved and Induced Air flotation (DAF and IAF) units
- Coalescing plate separators
- Multiple angle separators

### **API Separators**

The design of API separators is based on the criteria developed for the API during a three-year study begun in 1948 at the University of Wisconsin. These criteria were developed to be voluntary guidelines for designing separation systems. API separators are designed to remove 150 micron and larger droplets and to generate effluent oil concentrations down to about 150 mg/L (14). Because this does not meet the requirements of the Clean Water Act, API separators are usually not adequate to meet environmental requirements for discharge. In addition, the large size required by the API separation design criteria leads to Reynolds Numbers on the order of  $10^4$  to  $10^5$ , ensuring that turbulence is present, thus contributing to mixing and subsequent re-entrainment of oil droplets (21). API separators are normally provided as part of the refinery operation because of the large amount of recoverable oil in refinery wastewater (19).

Oil droplets rise according to Stokes's law, but considerable turbulence and short-circuiting usually prevails in an API separator (22). For this reason, an API separator will usually not perform as well as predicted by Stokes's law, because Stokes's law is only valid under laminar flow conditions. Variable turbulent and/or short-circuiting operating conditions can also result in variable effluent oil and grease concentrations.

Rebhun and Galil (23) reported oil removals by an API separator in an oil refinery to be about 70%, with effluent hydrocarbon content averaging about 75 mg/L, although the content varied widely. Subsequent treatment with flocculation and a Dissolved Air Flotation (DAF) unit reduced the concentration to about 20 mg/L. To make this separation, about 40 mg/L of aluminum sulfate (alum) was required and 300 m<sup>3</sup>/day of sludge was produced.

Hydrocarbons in effluent water from API separators have been reported to be as

low as 20 mg/L, but average about 35-60 mg/L with quantities up to 115 mg/L reported (13). A schematic of a typical API separator is illustrated in Figure 1.

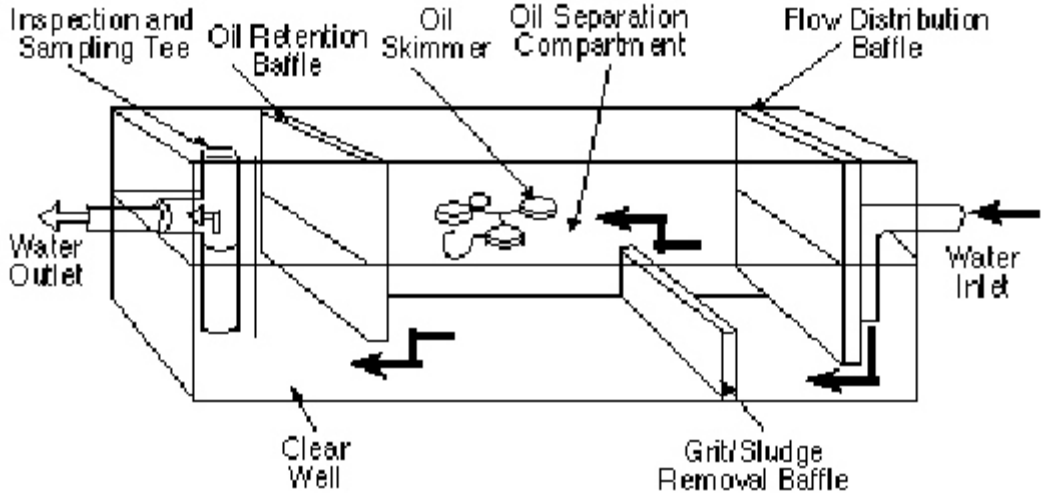

Figure 1: Typical API Separator

### Flocculation Units

Chemical flocculation units may be used where it is desirable or required to remove additional suspended solid particles not removed by gravity separation and/or to remove particulate sulfides in the water. The flocculants used are generally aluminum or ferric salts. They are added to the water and the resulting mixture gently agitated and circulated until the floc reaches a settleable size. This must be carried out at somewhat elevated pH conditions of 8.5-9.0. Oil, solid particles and precipitated sulfides are enmeshed in the ferric or aluminum hydroxide floc thus generated (13).

Kalbfus (24) discussed results of treatment of oil refinery effluent in European refineries and mentioned as an example that in one refinery the n-C16H34 concentration exiting the API separator was 80 µg/L, and chemical flocculation decreased this to about 0.4 µg/L. Subsequent biological treatment decreased this to about 0.2 µg/L and all hydrocarbons down to 0.5 µg/L.

#### Advantages:

Some sulfides are removed along with the oil and solid particles and some removal of oxygen demand is accomplished. It is possible to attain relatively low levels of hydrocarbons in the effluent water.

#### Disadvantages:

Large quantities of hydrocarbon containing sludge are produced because about 100 mg/L of flocculant chemical is required (13). Purchasing the flocculant chemicals can constitute a substantial operating expense. Oil removed in this step is difficult to

recycle because it is mixed with the inorganic components of the sludge.

## **Air Flotation Separators**

Air flotation separators, both dissolved air flotation (DAF) and induced air flotation (IAF) separators utilize air bubbles attached to the oil droplets to aid flotation of the oil. DAF and IAF are reported to be effective in treating some wastewater containing hydrocarbons close in specific gravity to water that are difficult to remove by gravity. The air bubbles reduce the net specific gravity of the hydrocarbon air composite droplets, thereby increasing the rise velocity of the droplets.

To assure maximum effectiveness in an air flotation separator, it is necessary to provide chemical coagulation and flocculation (22). Tests reported by Morrison (11) indicated no improvement in the operation downstream of a coalescing plate separator and suggested that the use of flotation is not recommended.

Advantages:

Heavy oils and solid particles may be removed effectively by the use of DAF OR IAF systems and low levels of hydrocarbons may be attained.

Disadvantages:

The capital cost of the equipment may be high, and purchasing the flocculant chemicals can constitute a substantial operating expense. Oil removed in this step is sometimes difficult to recycle because it is emulsified.

## **Coalescing Plate Separators**

Coalescing plate separators and other enhanced gravity separators were developed to reduce the distance the droplets must travel before capture, therefore reducing the size of the separator required (25). During the late 1950's, J. Cornelissen of Shell Oil at the Pernis refinery in the Netherlands developed the "tilted plate" type separator. The design was developed because conventional API separators required too much space and were not sufficiently efficient. The system was subsequently licensed to a Dutch firm for sale (25).

API publication 420, Section 2.1.5 (14) includes an example size calculation for an API separator treating a flow rate of 4490 US gpm, 105 degrees F, and a hydrocarbon specific gravity of 0.92. The calculations in the example indicate that 6 channels, each 18 feet wide and 105 feet long and with a water depth of 6 feet will be required. Calculations performed using a proprietary computer program indicate that with the use of 720 cubic feet of multiple angle coalescing plate media a better separation can be accomplished in two channels, each 15 feet wide and 21 feet long and with a water depth of 6-1/2 feet. The program assumes the use of proprietary media spaced at a nominal 1/2".

Advantages:

Advantages of coalescing plate separators over API separators are improved separation of both oil and sludge, laminar flow between plates, efficient flow distribution

not disturbed by wind, easy removal of sludge, self-cleaning properties, compact size, and low construction cost. Solid particles larger than 10 microns are almost completely removed (11). Hydrocarbon content in effluent water from coalescing plate separators has been reported to be as low as 10 mg/L, but averages between 10 and 30 mg/L (13).

Disadvantages:

Disadvantages include plugging if overloaded with solids, careful sealing required around the coalescing plates, and possible overflows of water and oil over the plates.

## Multiple Angle Separators

Multiple angle separators were developed to correct some of the problems associated with the use of coalescing plate separators, notably plugging with solid particles. Multiple angle separators utilize coalescing plates that are corrugated in two directions instead of only one. A typical multiple angle plate pack is shown in Figure 2. In testing after initial development of the multiple angle separators, it was found that oil removal was also enhanced over standard coalescing plate separators (26). It is thought that this is due to enhanced shedding of oil film from the plates, but no research has been completed to substantiate this mechanism.

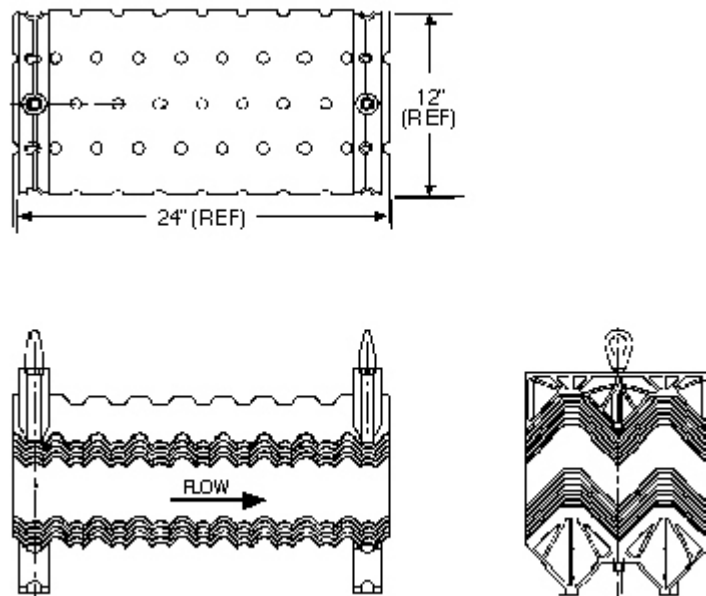

Figure 2: Typical Multiple Angle Coalescing Pack

Advantages:

Multiple angle separators are designed to ensure low Reynolds numbers and therefore laminar flow. In laminar flow regimes, Stokes's Law requirements are met and oil and solids removals are predictable. Multiple angle separators are efficient at removing the oil droplets from the water as a film on the underside of the plates well as

shedding the accumulated oil film to the top of the separator for removal and recycling. Other advantages of multiple-angle separators include low operating and maintenance costs because operation is by gravity. Short travel distances along the plates for solid particles before the particles can be dumped to the bottom of the separator help eliminate plugging by solids particles. Low concentrations of hydrocarbons in the effluent water may be attained (27).

**Disadvantages:**

Multiple-angle coalescing plate separators are sensitive to upstream conditions and not suitable for use in systems where the inlet water is provided by a centrifugal pump. They become large when the average inlet droplet size is small, the hydrocarbons to be separated are close in specific gravity to that of water, or the operating temperature is low (27). These are disadvantages of all gravity type separation type systems.

A typical installation of multiple-angle coalescing plates in an underground vault is shown as Figure 3. Some specific examples of the application of multiple angle separators are provided below.

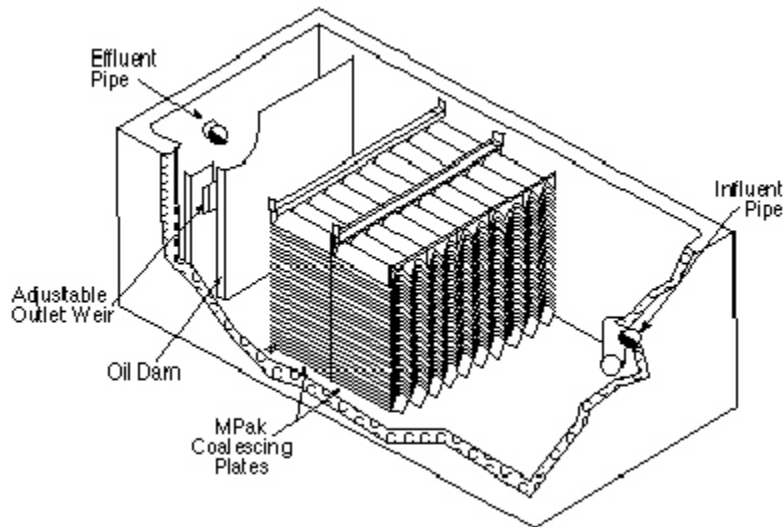

Figure 3: Typical Vault Installation Using Multiple Angle Separator Plates

## Examples of Operating Systems

*Stormwater from a large US refinery:*

In 1996, it was decided that the stormwater processing facilities in a large US refinery were not adequate to properly treat the flow expected during a large storm. The system consisted of two API type separators, each 18 feet wide and approximately 80 feet long. The original design for these separators was for a total of 8000 US gpm total, and it was desired to increase the design flow to 20,000 US gpm. The hydrocarbons to be removed are basically those expected to be washed off of soils within the refinery which have come into contact with oil over years of operation (28).

The two API separators were converted into four cells by adding multiple angle

coalescing media packs 90 inches tall, divider walls, and additional inlet/outlet piping so that the previous separators were cut approximately in half. New inlet perforated plate flow distributors were added and an existing horizontal pipe skimmer was relocated. Figure 4 provides a plan view of the revised system.

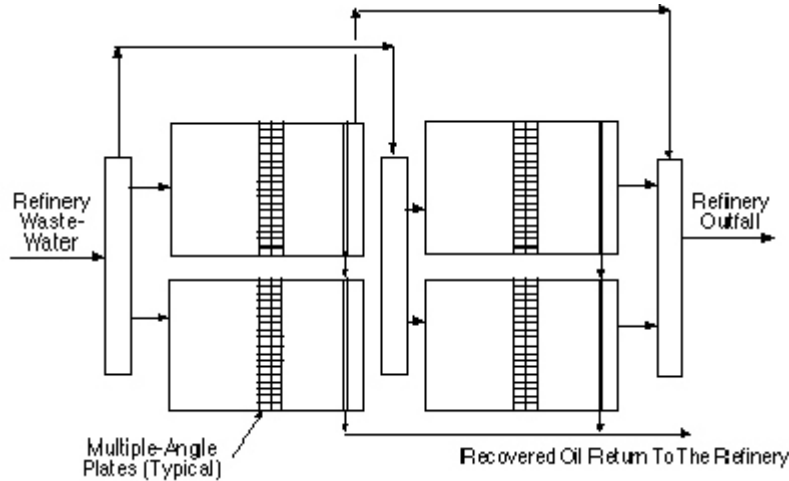

Figure 4: Simplified Flow Schematic, 20,000 GPM Refinery API Refit

Each separator cell was provided with a total of 408 cubic feet of effective multiple angle coalescing media. The normal flowing water level is 68 inches, but additional media was provided above the normal water line to process any flow that might occur in excess of the design flow. Performance would not be expected to meet the 10 mg/L effluent design criteria in case of a flow greater than design, but some removal would be expected.

Performance to the date of this writing has been very satisfactory. The average effluent concentration, based on data for a period from 1997 to early 1998 was approximately 6.77 mg/L. The flow weighted average was 4.85 mg/L (29).

*Wastewater from an Asphalt Refinery:*

In 1996, problems were experienced with unduly high concentrations of petroleum naphtha and phenols in a wastewater stream at Chevron USA's asphalt refinery in Seattle, WA. An oil-water separator system including a vertical tube coalescing pack was installed (30).

The effluent from the separator is cooled and treated with ozone for phenol removal in a large tank and subsequently passed through a treatment train including an API separator and an IAF unit before being discharged directly into Puget Sound. The original ozone injection point downstream of the separator was discontinued and the ozone injected directly into the tank. This was done because the flow rate is variable and treatment is difficult to control when the ozone is injected into the flowing stream, (30). A schematic of this system is included as Figure 5.

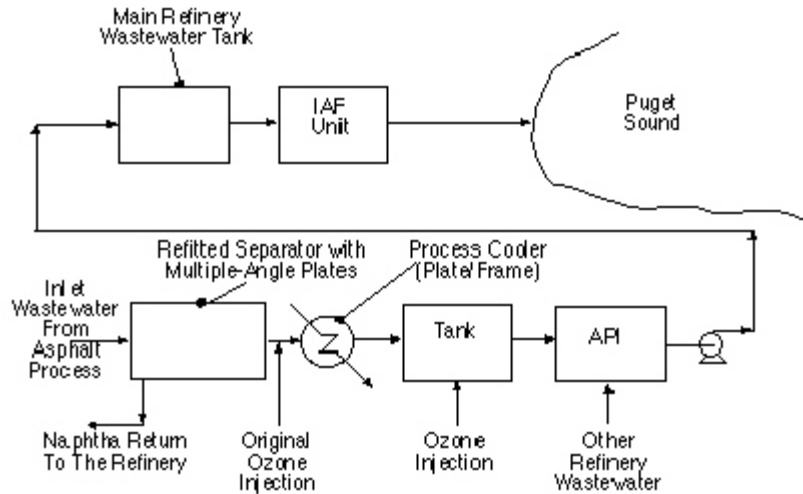

Figure 5: Flow Schematic – Chevron Refinery Wastewater

After installation of this system, effluent hydrocarbon problems continued and were traced to an incorrect choice of coalescing media. The vertical tube media chosen for the oil-water separator was not as efficient as necessary and not chemically compatible with the naphtha in the water stream. The naphtha gradually dissolved the media and caused it to warp and sag. The separator effluent water usually contained more hydrocarbons than the downstream processing system could effectively deal with and the media had to be replaced monthly because of the chemical attack (31).

The vertical tube coalescing media was subsequently replaced with more efficient multiple angle coalescing plates. The chemical attack problem was solved by the use of coalescing plates molded of polyoxymethylene plastic, generically referred to as acetal. At the time of this paper's writing the acetal plates have been in service for over a year and exhibit no signs of chemical attack. The phenol content of the effluent is consistently less than 1 mg/L (30).

*Wastewater from refinery tank farms:*

In early 1998, two existing stormwater treatment vault-type separators, similar in design to API separators, in the tank farm at a large refinery in the Puget Sound, Washington area were fitted with multiple angle coalescing plates to enhance the separation efficiency. Each separator is eight feet wide and sixteen feet long and was fitted with 224 cubic feet of high efficiency media. Design conditions were an estimated 100 mg/L of hydrocarbon inlet with a requirement for 10 mg/L or less outlet hydrocarbon content. The design conditions were chosen based on refinery experience and an estimation of what the "worst case" conditions might be. The 10 mg/L or less requirement was necessary to meet the Washington State regulations as described in the Stormwater Management Manual for the Puget Sound Basin. Although the separators have only been in service a brief time, preliminary data indicates that the separators are performing satisfactorily (32).

*Wastewater from Nigerian refinery units:*

In 1993, wastewater treatment units were installed at the Yola and Makudi refineries in Nigeria. These units were designed as two-stage units with a combination sludge trap and gross oil recovery stage followed by a multiple angle coalescing stage to perform the fine separation. Each system consisted of two separators in parallel for ease of maintenance, and the two systems share a common recovered oil tank. The systems were designed in modular fashion for ease of shipment and installation. Figure 6 shows the layout of these systems (33). The units were designed for water flows up to 250 M<sup>3</sup>/hr, 500 mg/L of 0.90 specific gravity hydrocarbons in the influent, and effluent quality of 15 mg/L or less. The units are deemed to be operating satisfactorily (33).

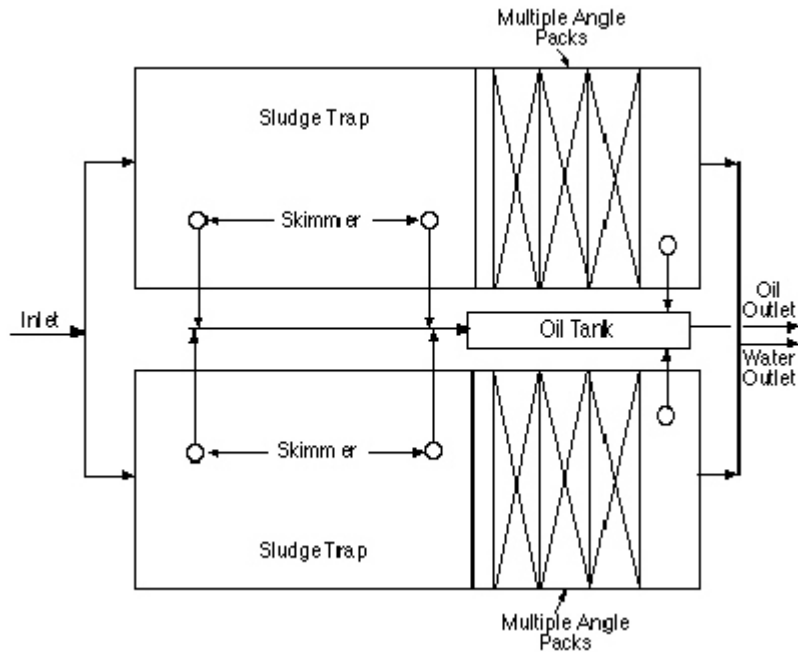

Figure 6: Nigerian Refinery Units

*Wastewater from a Spanish Refinery:*

In 1997, multiple angle coalescing plate type wastewater treatment units were installed at a refinery in Algeciras, Spain. These units were designed as pressure vessels to avoid possible losses of hydrocarbons to the atmosphere. The systems were designed with large oil storage capacity to accommodate possible unplanned releases. Figure 7 shows the layout of these systems. The units were designed for water flows up to 60 M<sup>3</sup>/hr with as much as 5 M<sup>3</sup>/hr of 0.90 specific gravity hydrocarbons. Design effluent hydrocarbon content was set at 15 mg/L or less at any inlet hydrocarbon concentration less than 1000 mg/L. The units were designed to remove all droplets greater than 47 microns. The units are deemed to be operating satisfactorily (33).

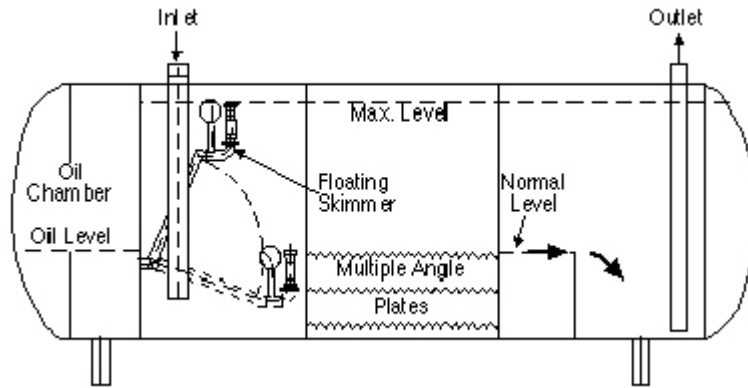

Figure 7: Spanish Refinery unit

*Wastewater from a Refinery in the Philippines:*

The 1959 vintage water treatment system at a large Philippine refinery was redesigned in 1996 and a multiple-angle coalescing system, a dissolved air floatation (DAF) unit, and a biological wastewater treatment system were added. The existing API pits were upgraded to DAF chambers and the impounding basin was dug out and re-lined. The upgraded system was required to process about 2500 gpm of process water from the refinery, tank bottoms, and ships' ballast water in addition to 5000 gpm of stormwater from the refinery and tank farm. The new system was designed to remove not only oil, but also some suspended solids, phenols, and BOD/COD at flows up to a design maximum of 10,000 US gpm.

Any excess flow is diverted to a retention pond for later processing. In the event flow exceeds the capacity of the retention pond, excess water is passed directly to the ocean by an underflow arrangement to ensure the pond retains any large amounts of hydrocarbons. Figure 8 is a schematic of the overall system.

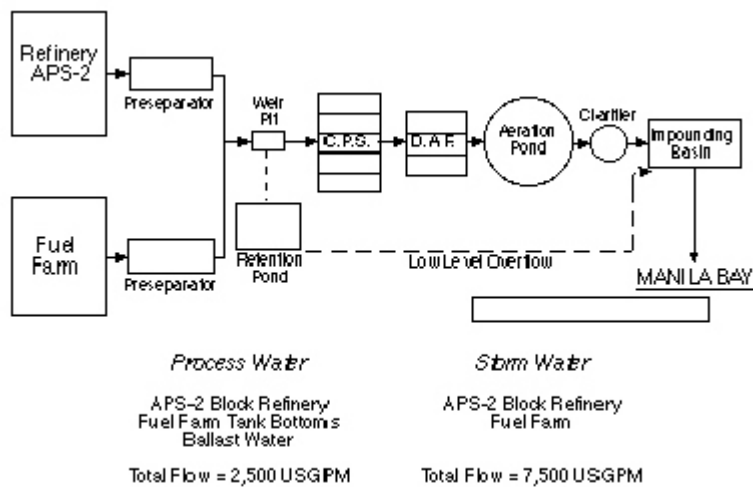

Figure 8: Philippine Refinery Wastewater Flow

Flow into the pre-separation basins was designed for normal conditions of 5000 to 6000 mg/L of oil but can reach 72000 mg/L during the 7-10 day per year service period. It was expected during the design that water exiting the pre-separation basins would be about 3500 mg/L.

The multiple-angle coalescing plate system was designed to produce an effluent quality of 50 mg/L or less. The multiple-angle separator system, designed as a pretreatment system for the DAF section, consists of 5 concrete chambers, each with 36 multiple-angle separator packs arranged in two rows of 18 packs each. The plate packs were mounted in “cages”, each cage containing 6 packs. The cages were designed to “anchor” the packs in the event of high flows and also to facilitate easy cleaning.

Normal operating flow rates have ranged from 900 to 3000 gpm. Operating data from samples taken during the Spring of 1998 are shown in Table 1.

Date of Sample	Influent Oil Content, mg/l	Effluent Oil Content, mg/l	Percent Removal
January 25, 1998	12,315	38	99.69%
February 8, 1998	9,875	23	99.77%
March 15, 1998	38,000	69	99.82%
April 22, 1998	23,768	54	99.77%
May 15, 1998	17,159	45	99.74%
Average	20,223	46	99.77%
Design	3,500	50	98.57%

Even though the influent concentration was much more than the design concentration, the average multiple-angle separator effluent of 46 mg/L was still less than the design goal of 50 mg/L. Some of the good performance can be attributed to the less than design flow rates.

The DAF system was designed for an influent hydrocarbon concentration of 50 mg/L or less, with a suspended solids concentration of less than 100 mg/L. Table 2 shows the performance of the DAF system.

The DAF system performance has also been satisfactory, with effluent quality better than design requirements in all cases. The lower than design flows probably also helped the performance of the DAF system.

Some difficulties in removing high gravity, high viscosity oil from areas of the system using belt style skimmers were encountered, but an alternative system using floating oil skimmers proved successful and the overall system is now operating within design specifications (34).

Table 2. Dissolved Air Flotation (DAF) Unit Performance, Philippine refinery			
Date of Sample	Influent Oil Content, mg/l	Effluent Oil Content, mg/l	Percent Removal
January 25, 1998	38	4	89.47%
February 8, 1998	23	3	86.96%
March 15, 1998	69	7	89.86%
April 22, 1998	54	8	85.19%
May 15, 1998	45	6	86.67%
Average	46	6	86.96%
Design	50	10	80.00%

## The Future of Wastewater Treatment in Refineries

Responsible industries like the oil refining industry will certainly continue to improve operations to minimize the amounts of hydrocarbons in wastewater streams. Some hydrocarbons will still enter wastewater streams because of small spills and leaks, and it will be necessary to recover these to further reduce the amount of hydrocarbons in refinery effluents.

It is expected that new designs, and refinements of old designs will be used to provide better treatment, and a great deal of engineering effort will be expended to minimize energy and chemical use. This will provide benefits in cost reductions as well as reductions in chemical sludge (and therefore waste disposal costs) produced. The ideal treatment system would be one that would not require any energy to operate, would require no chemical addition, and would not generate any sludge while recovering 100% of the hydrocarbons in the waste stream. While it is not likely that we will ever be able to design such ideal systems, we can already approximate these systems with the use of today's sophisticated enhanced gravity separation systems.

## Summary and Conclusions

Major improvements in treatment of refinery wastewater have been made in the decades since the design of the first API separators and further improvements can be expected.

The removal of hydrocarbons from refinery wastewater may be accomplished by various designs that have been developed over the last fifty years since the original API

studies were completed. These designs have various advantages and disadvantages. It is up to the design engineers to determine which systems are most effective in any given situation, and it is likely that the designs offering the best hydrocarbon recovery with lowest operating and maintenance cost will be chosen most frequently.

Because API separators do not provide effluent quality sufficient to meet the regulations in many countries, especially the United States, it is often necessary to utilize other technologies to enhance the operation of separators and remove oil to less than the levels that would generate a sheen. In many instances as illustrated above, multiple-angle coalescing plates provide a good solution for many refinery effluent problems because they exhibit predictable performance acceptable to regulatory engineers, operate by gravity and thus require no energy input, and have no moving parts, therefore requiring minimal maintenance.

## **Acknowledgments**

The authors would gratefully like to thank the engineers who provided the information and data for the discussions of operating units.

## References Cited

1. Forbes, R.J., Studies in Early Petroleum History, Leiden, Netherlands, E.J. Brill Co. (1958).
2. Nelson, W.L., Petroleum Refinery Engineering, 4 ed., New York, NY, McGraw-Hill Book Publishing Company (1969).
3. Lysogorova, I.K., "Purification of the Oil Industry's Waste Water Which Pollutes Bakings Bay", in U.S.S.R. Literature on Water Supply and Pollution Control, ed. Levine, B.S., Washington, D.C., US Public Health Service (1961).
4. Nöh, H., "Separators and Emulsion Separation Systems for Petroleum, Oil, and Lubricants," in proceedings of the Pretreatment in Chemical Water and Waste Water Treatment, 3rd Gothenburg Symposium, New York, NY, Springer-Verlag (1988).
5. Jorgensen, S.E., Industrial Waste Water Management, New York, NY, Elsevier Scientific Publishing Company (1979).
6. United States Supreme Court, "United States v. Pennsylvania Industrial Chemical Company," 411 U.S. 655, (1973).
7. Chieu, J. and Foster, S., "Improve Storm Water Management for Refineries - Part 1," *Hydrocarbon Processing*, **72**, 73-9 (1993).
8. Romano, F., Oil and Water Don't Mix: The Application of Oil-Water Separation Technologies in Stormwater Quality Management, Seattle, WA, Office of Water Quality, Municipality of Metropolitan Seattle (1990).
9. Hunter, J.V. et al., "Contribution of Urban Runoff to Hydrocarbon Pollution," *Journal WPCF*, **51**, no. 8, 2129-38 (1979).
10. Kirkup, W.M., "Refinery Oil/Water Separation Equipment and Its Applications," *Filtration and Separation*, **14**, 259-65 (1977).
11. Morrison, J., "Tilted-Plate Separators for Refinery Waste Water," *Oil and Gas Journal*, **68**, no. 50, 86-8 (1970).
12. Twardowski, G., to Kirby Mohr. (July 1998).
13. Blokker, P.C., "Prevention and Abatement of Water Pollution in Refineries", in Water Pollution by Oil, ed. Hepple, P., 26-36, London, Institute of Petroleum (1970).
14. American Petroleum Institute, Design and Operation of Oil-Water Separators, Publication 421, Washington, D.C., American Petroleum Institute (1990).
15. Mohr, K.S., "Effective Pretreatment for Hydrocarbon/VOC Removal," in proceedings of

- the WEF Industrial Wastes Technical Conference, Washington, D.C., Water Environment Federation (1998a).
16. Horenstein, B., The Appearance and Visibility of Thin Oil Films on Water, Cincinnati, OH, US Environmental Protection Agency (1972).
  17. Washington State Department of Ecology, Stormwater Management Manual for the Puget Sound Basin, Tacoma, WA, Washington State Department of Ecology (1991).
  18. Canadian Coast Guard, Standard for 5 PPM Bilge Alarm (for Canadian Inland Waters), Ottawa, Canada, Canadian Coast Guard, TP 12301E (1995).
  19. Bush, K.E., "Refinery Wastewater Treatment and Reuse," *Chemical Engineering*, **83**, no. 8, 113-8 (1976).
  20. Perry, J.H. et al., Chemical Engineers' Handbook, 4 ed., New York, NY, McGraw-Hill Book Company (1963).
  21. Branion, R., "Principles for the Separation of Oil Drops From Water in Gravity Type Separators", in Oil in Freshwater: Chemistry, Biology, Countermeasure Technology, ed. Vandermuelen, J.H. and Hrudley, S.E., 431-42, New York, NY, Pergamon Press (1987b).
  22. Ford, D.L. and Elton, R.L., "Removal of Oil and Grease From Industrial Wastewaters," *Chemical Engineering*, **84**, 49-56 (1977).
  23. Rebhun, M. and Galil, N., "Technological Strategies for Protecting and Improving the Biological Wastewater Treatment From a Petrochemical Complex," *Water Science and Technology*, **29**, no. 9, 133-41 (1994).
  24. Kalbfus, W., "Analyze the Hydrocarbons in Liquid Refinery Wastes," *Hydrocarbon Processing*, **65**, 77-9 (1986).
  25. de Kok, F. and Marson, H.W., "Tanker Ballast Water Meets Tough Treating Specs," *Oil and Gas Journal*, **76**, no. 49, 92-7 (1978).
  26. Conley, D., HEROWS Unit Test Report, Tulsa, OK, Facet International (1992).
  27. Mohr, K.S., "A New Type of High Efficiency Oil-Water Separator for Better Water Quality Management," in proceedings of the Pacific Northwest Pollution Control Association Meeting, Boise, ID, PNPCA (1992).
  28. Zeffiro, J., Personal communication from SE Technologies, to Kirby Mohr. (27 March 1996).
  29. Duz, W.D., Personal communication from Consultant, to Kirby Mohr. (1998).
  30. Rogers, R., Personal communication from Consultant, to Kirby Mohr. (9 September 1998).
  31. Kennedy, G., Personal communication from Consultant, to Kirby Mohr. (August 1998).

32. Leonard, J., Personal communication from Flow Products Co., to Kirby Mohr. (9 August 1998).
33. Sanchez, T., Personal communication from Facet Iberica, to Kirby Mohr. (17 July 1998).
34. Clancy, M., Personal communication from Baldwin Industrial Systems, to Kirby Mohr. (14 August 1998).